

---

## **MiChroSat 2403**

Wireless Innovation

Version 1.0.2

Release Date 02/11/10

---

**Revision History**

Revision	Date	Comment
V0.1	29th August 2010	TM – Initial re-draft for MiChroSat 2403
V1.0	18 <sup>th</sup> Sept 2010	<b>Initial Release</b>
V1.0.1	05 <sup>th</sup> October 2010	TM – Minor modifications.

**Trade Mark Notice**

The following are Trade Marks or Registered Trade Marks of Wireless Innovation Ltd: MiChroSat, MiChroSat Controller, MiChroFace, and the MiChroSat Device.

© 2010 Wireless Innovation Ltd. Wireless Innovation products and solutions are protected by intellectual property right, including copyright, international patent applications and trade marks. All rights reserved.

Ongoing development programmes means that all specifications may be subject to change without notice.

## **Standards Compliance**

The MiChroSat 2403 modem and the Iridium 9522B LBT module within have been designed to comply with the standards for Radio Emissions Compliance, Electromagnetic Compatibility, and AC Safety in the United States, European Union and Canada.

### **CE Compliance**

This product when marked with the CE symbol, complies with the European Community Council Directive for R&TTE, 99/5/EC, provided the installer/user adheres to the instructions detailed in this manual. This product is in compliance with the applicable ETSI standards. Compliance with the requirements of ETSI EN 301 489 requires the use of a shielded data cable.

### **FCC Compliance**

This device has been certified under 47 CFR Part 25 as FCC ID:Q639522B. It also complies with Part 15 of the FCC Regulations. Operation is subject to the condition that this device does not cause harmful interference.

Any changes or modifications including the use of a non-standard antenna, not expressly approved by the party responsible for compliance could void the user's authority to operate the equipment.

**NOTE:** To comply with FCC RF exposure requirements, a minimum separation of 20cm is required between the antenna and any persons.

### **Power Safety Precaution.**

**Warning:** Please isolate power supply from the MiChroSat 2403 before removing cover.

## RF SAFETY PRECAUTIONS

### Exposure to Radio Frequency Signals

The MiChroSat 2403 satellite modem is a low power radio transmitter and receiver, When it is ON it receives and also sends out radio frequency (RF) signals.

International agencies have set standards and recommendations for the protection of public exposure to RF electromagnetic energy.

- International Commission on Non-Ionizing Radiation Protection (ICNIRP) 1996
- Verband Deutscher Elektrotechniker (VDE) DIN-0848
- United States Federal Commission, Radio Frequency Exposure Guidelines (1996)
- National Radiological Protection Board of the United Kingdom, GS 11, 1988
- American National Standards Institute (ANSI) IEEE. C95. 1-1992
- National Council on Radiation Protection and Measurements (NCRP). Report 86
- Department of Health and Welfare Canada. Safety Code 6

These standards are based on extensive scientific review. For example, over 120 scientists, engineers, and physicians from universities, government health agencies, and industry reviewed the available body of research to develop the updated ANSI standard.

The design of the MiChroSat 2403 system complies with these standards when used with an approved antenna according to the following conditions:

- To assure that radio frequency (RF) energy exposure to bystanders is lower than that recommended by the adopted standard, Operate the MiChroSat Modem only when bystanders are at least 20 cm (8 inches) away from a properly installed externally-mounted antenna.
- DO NOT operate the MiChroSat modem unless all RF connectors are secure and open connectors are properly terminated.
- DO NOT operate the MiChroSat modem near electrical blasting caps or in a potentially explosive atmosphere.
- Operation around Medical Devices - Persons with Pacemakers: The Health Industry Manufacturers Association recommends that a minimum separation of 15 cm (6” inches) be maintained between the modem and a pacemaker to avoid potential interference with the pacemaker. These recommendations are consistent with the independent research by and recommendations of Wireless Technology Research. Turn the modem OFF immediately if you have any reason to suspect that interference is taking place.  
Other Medical Devices If you use any other personal medical device, consult the manufacturer of your device to determine if it is adequately shielded from external RF energy. Consult your physician to determine compatibility with your medical device.

- All equipment should be serviced and installed only by a qualified technician.



**Contents**

**1 OVERVIEW.....9**

1.1 SYSTEM OPERATION .....9

    1.1.1 Asynchronous Data.....9

    1.1.2 Direct Internet Connectivity ..... 11

**2 GENERAL PRODUCT DESCRIPTION .....12**

2.1 MiCHRO SAT 2403 .....13

    2.1.1 Features.....13

    2.1.2 Power Consumption.....13

    2.1.3 Front Panel Layout.....14

    2.1.4 Interface Connectors.....14

    2.1.5 MiChroSat Connector Pin Outs.....15

    2.1.6 Indicator LEDs .....17

    2.1.7 Program Mode Switch .....17

    2.1.8 RF Interface Specifications.....18

    2.1.9 Antenna Specifications.....18

    2.1.10 Radio Characteristics .....19

    2.1.11 RF Cable Requirements.....19

    2.1.12 Antenna Location.....20

    2.1.13 Analogue Audio Specifications .....22

    2.1.14 SIM Interface Specifications.....22

    2.1.15 Optional Power Management Facility.....22

    2.1.16 Environment Specifications .....22

    2.1.17 Dimensions .....23

    2.1.18 Installation Guidelines.....24

2.2 RS-232 THREE WIRE SERIAL OPERATION .....25

2.3 SETTING RS232 INTERFACE RATES .....25

2.4 SETTING THE MODEM TO AUTO ANSWER INCOMING DATA CALL.....25

2.5 PERMANENTLY STORING CONFIGURATION SETTINGS .....25

2.6 SHORT MESSAGE SERVICE (SMS) .....26

2.7 SHORT BURST DATA.....26

2.8 PHONE NUMBERS .....27

2.9 USE OF AT COMMANDS WITH THE MiCHRO SAT MODEM.....27

2.10 MODEM MODE OF OPERATION .....27

2.11 COMMAND ENTRY .....28

2.12 MODEM RESPONSES CODES.....29

**3 COMMONLY USED MODEM AT COMMANDS.....30**

**4 CALL SCENARIOS.....32**

4.1 MiCHRO SAT TO MiCHRO SAT CALLS .....32

    4.1.1 Configuring the Originating MiChroSat Modem.....32

    4.1.2 Configuring the Terminating MiChroSat Modem.....32

4.2 MiCHRO SAT TO PSTN CALLS.....33

    4.2.1 Configuring an Originating MiChroSat Modem (Calling to PSTN).....33

    4.2.2 Configuring a Terminating MiChroSat Modem (Called From PSTN) .....34

**5 HYPERTERMINAL CONFIGURATION.....35**

5.1 ORIGINATING CALLS FROM A MiCHRO SAT MODEM .....35

5.2 ORIGINATING CALLS FROM A PSTN MODEM .....36

5.3 CONFIGURING A MiCHRO SAT MODEM AS THE TERMINATING MODEM .....39

**6 MiCHRO SAT CONTROLLER CONFIGURATION GUIDE .....42**

6.1	CONTROLLER DESCRIPTION .....	42
6.2	USER CONFIGURABLE SOFTWARE - MICHRoFACE.....	43
6.2.1	<i>Minimum PC requirements</i> .....	43
6.2.2	<i>Installation</i> .....	43
6.2.3	<i>General Screen Layout</i> .....	45
6.2.4	<i>Configuring Power Saving Modes</i> .....	46
6.2.5	<i>Michroface - Menu Pull Down Options</i> .....	54
6.2.6	<i>Glossary of Parameters Used within Configuration Software</i> .....	54
<b>7</b>	<b>TROUBLESHOOTING .....</b>	<b>57</b>
7.1	FREQUENTLY ASKED QUESTIONS .....	57
7.1.1	<i>How can I tell if my MiChroSat Modem is registered on the satellite network?</i> .....	57
7.1.2	<i>How can I check my MiChroSat modem signal strength?</i> .....	58
7.1.3	<i>How can I check if my MiChroSat modem is waiting for a PIN code?</i> .....	58
7.1.4	<i>How do I remove the PIN code from my SIM?</i> .....	59
7.1.5	<i>My Terminal Software will not communicate with the MiChroSat Modem?</i> .....	59
7.1.6	<i>The Michroface software will not communicate with the MiChroSat Modem?</i> .....	59
7.1.7	<i>How should I format the number I am trying to dial from my MiChroSat Modem?</i> .....	60
7.1.8	<i>How do I configure my MiChroSat modem to automatically answer incoming calls?</i> .....	60
7.1.9	<i>Are there any special requirements when making calls to/from MiChroSat Modems from PSTN or GSM?</i> 60	
7.1.10	<i>Are there any test numbers I can call from my MiChroSat modem to verify my configuration? .....</i>	61
	<i>The Iridium satellite network provides a dedicated test number for voice/audio services that may be called from your MiChroSat modem (if voice has been provisioned) using the dedicated voice handset . .....</i>	61
	<i>Voice Test Number: 00-1-480-752-5105 .....</i>	61

# 1 OVERVIEW

MiChroSat is a low data rate communications solution developed by Wireless Innovation for deployment in remote locations. Operating via LEO (Low Earth Orbit) satellite networks, MiChroSat provides continuous total global coverage, allowing the modem to be operated anywhere on the earth with a clear view of the sky.

MiChroSat offers data connectivity either via ‘async’ type modem to modem connections or direct internet dial-up connectivity via a bespoke satellite optimized ISP service.

The system can also provide “closed network” SMS messaging services and also the unique Short Burst Data Messaging Service using an optimized packet based messaging service.

## 1.1 System Operation

### 1.1.1 Asynchronous Data

When providing async data services, the MiChroSat modem can be interfaced directly into existing applications utilizing PSTN or GSM modems. The modem provides async data connectivity at data rate of 2400bps. The MiChroSat system supports both Modem to PSTN/GSM connections and Modem to Modem connectivity.

The MiChroSat modem supports the full ‘Hayes’ AT command set allowing existing applications to be easily interfaced to the modem.

- **MiChroSat Modem to MiChroSat modem**

MiChroSat provides direct modem to modem connectivity, allowing one modem to call another directly with no terrestrial network connection. This method of configuration allows a number of modems in the field to call (or to be called) directly via a bank of modems located at the customers premises. This provides a secure independent communications network, removing any reliance on the existing terrestrial infrastructure. Figure 1.1a) shows a typical modem to modem configuration.

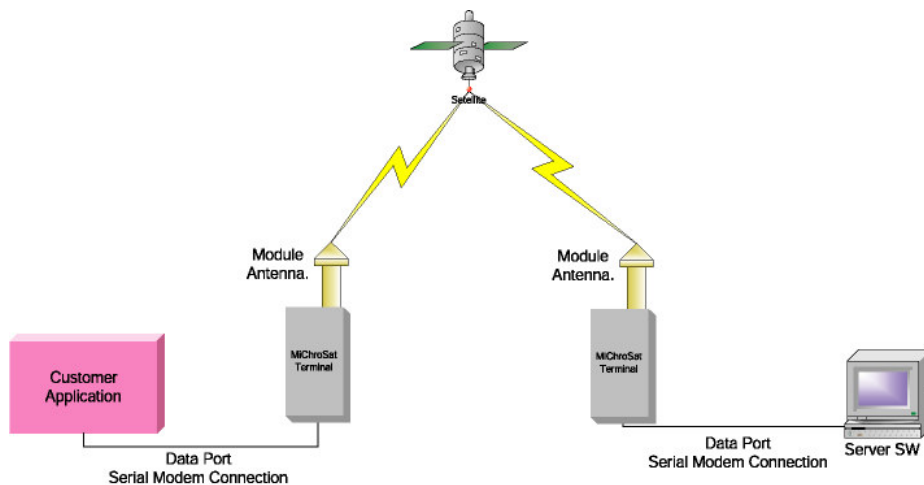

**Fig 1.1a)** Direct Modem to Modem Communication

- **Modem to PSTN**

Figure 1.1b) shows a typical application, where a MiChroSat modem is being used to extend a PSTN dial-up application to locations where there is no PSTN connectivity or GSM coverage. The MiChroSat modem can dial directly to PSTN/GSM numbers or can wait in 'auto-answer' mode to receive calls from PSTN/GSM as required.

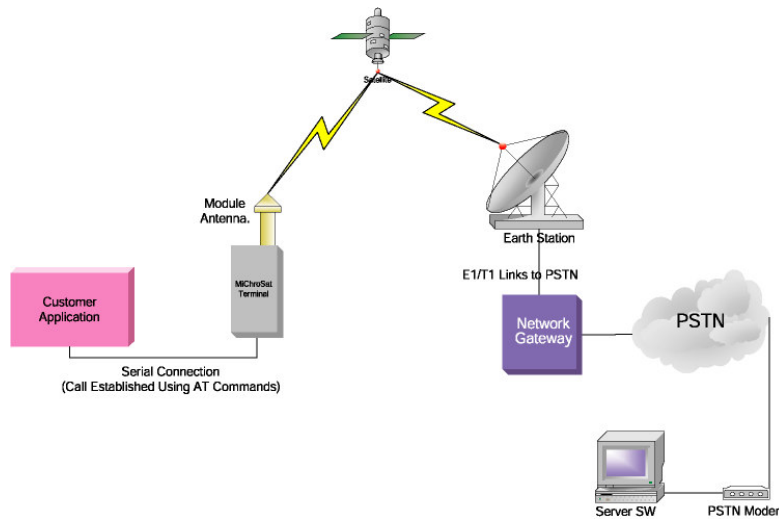

**Fig 1.1b)** MiChroSat to PSTN Network Call Configuration

If dialing from PSTN to MiChroSat, it is always recommended that a direct analogue subscriber line (POTS Line) is used to place/receive calls as PABX's may cause compatibility issues from PSTN modem to Iridium Gateway, for reference the bearer service provided by any PABX circuit must be 3.1KHz audio for successful operation.

It should also be noted that many Least Cost Call routing services offered by service providers use Voice Over IP (VOIP) circuits which do not support circuit switched data calls.

The end-to-end data call quality and probability of connection is governed by the ability of the modem relay equipment at the satellite gateway to synchronise with modems at the originating location. Modem synchronisation is directly impacted by voice compression that is used by international telephony carriers.

**For optimal reliability and connectivity, Wireless Innovation Ltd recommends that wherever practically possible closed network calling from MiChroSat modem to MiChroSat modem be used.**

### 1.1.2 Direct Internet Connectivity

The MiChroSat modem can be configured to provide a direct connection to the internet at 2400bps without having to dial a traditional ISP via PSTN. To access the internet the modem dials a specific access number using standard Hayes 'AT' commands and the call is answered by the gateway via a satellite optimized ISP service provided by Wireless Innovation Ltd.

A PPP session is established connecting the user directly to the internet. Once the terminal is connected it allows the full suite of IP protocols to be used such as WWW, FTP, SMTP and Telnet. A typical direct internet connectivity application is shown in figure 1.1.2a.

Direct internet connectivity allows customer applications to operate using standard IP communications allowing applications to be quickly migrated into satellite applications. The direct internet connectivity reduces call costs by optimising the PPP negotiation process allowing the actual call duration to be reduced.

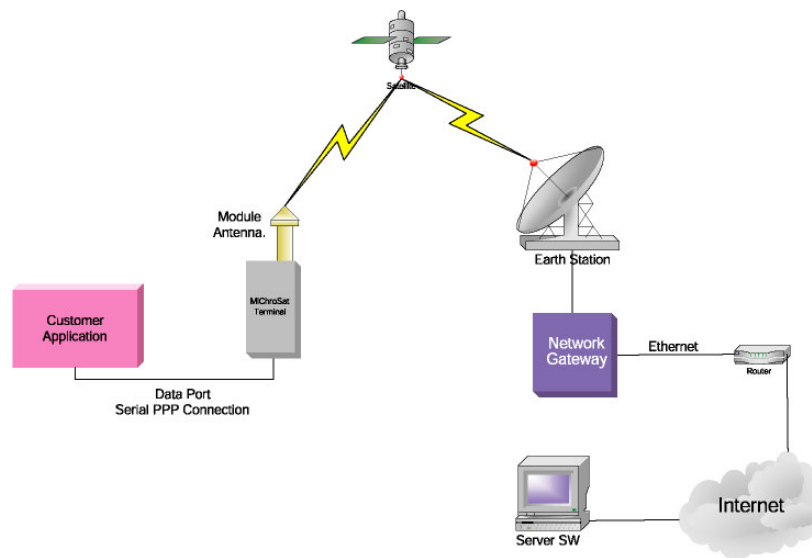

Fig 1.1.2) Direct Internet Connectivity via MiChroSat

## 2 GENERAL PRODUCT DESCRIPTION

The MiChroSat remote satellite terminal is a modular system and may be provided in a variety of configurations to fit any customer application.

Options Available Include:

**MiChroSat 2403**

*Modem in IP 44 enclosure includes In-Built Intelligence with power saving mode of operation, full isolation between the user and modem serial interface and voice Interface.*

**Developer Kit**

*Modem in IP 44 enclosure with developer kit (PSU, Manuals and all cables required for application testing).*

The MiChroSat remote satellite terminal is typically supplied fully integrated into an IP-44 enclosure (as shown below), however other designs such as re-enforced polyester street furniture bollard enclosures are also available upon request. The MiChroSat 2403 is designed to be powered by a +9V to +30V DC supply, it also incorporates intelligent power management to allow it be deployed in extreme remote applications where a one-year battery/solar/wind power solutions can be utilized.



**MiChroSat 2403**

**2.1 MiChroSat 2403**

**2.1.1 Features**

- Modem packaged in an IP-44 enclosure with industry standard connectors to ensure ease of connectivity.
- Modem has standard 9 pin RS 232 interface.
- Full RS232 serial isolation between user and modem interfaces.
- Modem is controlled via standard Hayes AT commands.
- Automatic programming of the modem initialization string at power on.
- Voice module (requires additional handset and voice provisioning of included SIM card)
- Supports standard RS 232 signalling levels.
- Modem may be configured for basic 3 wire RS 232 operation.
- Supports DTE interface speeds of 1200 – 19,200 bps.
- Intelligent power management features to power down/wake up modem when idle or under application control, and to set windowing modes to enable automatic power on/off at user defined times.
- Supplied with Antenna and suitable RF cable.

**2.1.2 Power Consumption**

The following are nominal figures based on operation of the MiChroSat 2403 at 12Vdc, exact power consumption will be dependent on the deployment scenario:

- “Sleep” Mode: 0.12W
- Idle: 1.5W
- Transmit: 12W (peak), 6W (average)

Parameter	Value
Main Input Voltage Nominal	+9.0 to +30Vdc (Nominal inputs 12 VDC or 24VDC)
Main Input Maximum Voltage Ripple	40mv p-p

**Please note that for optimal operation the DC source/power supply should be capable of providing 2.5A at +9VDC.**

### 2.1.3 Front Panel Layout

The front panel of the MiChroSat 2403 contains the interface connectors, programming switch and the indication LEDs. All connectors are labelled on the front panel for ease of identification.

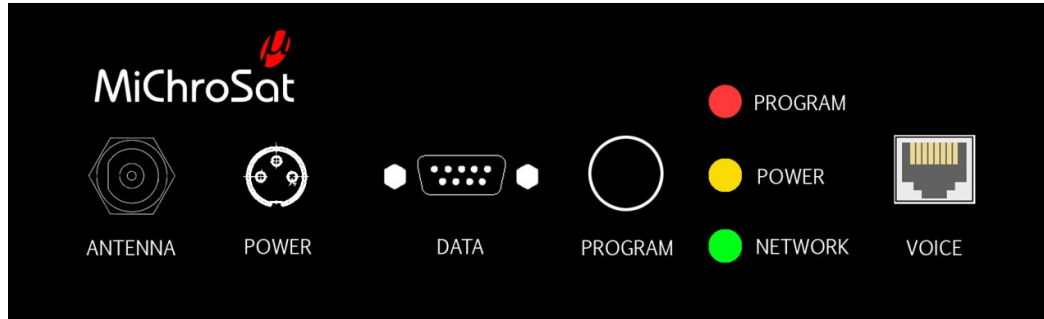

MiChroSat 2403 – Front Panel

The programming switch is used to switch the MiChroSat 2403 between normal modem operation and configuration modes.

### 2.1.4 Interface Connectors

**NOTE:** The following defines the connectors required to interface to the MiChroSat 2403 modem.

- RF Cable & Default Antenna Connector – TNC Male
- Multi-Interface (Serial Data) Connector – 9 pin D-type Male
- Power Connector – Amphenol: C091-31H003-100-2 – 3 pin Male
- Voice handset Connector – RJ45 Socket IP-65.. RJ-45 Connector (Supplied with DPL handset)

**2.1.5 MiChroSat Connector Pin Outs**

**2.1.5.1 DC Power Connection:**

Power Connector 3 Pin Amphenol Connector	Signal Name
1	Gnd
2	N/C
3	+Vcc

**NOTE:** Default colour coding for power cable supplied with the modem is White (Vcc), Black (Gnd) however always test the cable prior for correct polarity prior to connecting to the modem.

**2.1.5.2 Voice Handset Connection:**

Voice Handset RJ45 MIL Spec. Connector	Signal Name
1	MIC Audio
2	DC GND
3	On/Off
4	SPKR Audio
5	Iridium Bus Control (output to Handset)
6	Iridium Bus Control (input from Handset)
7	Ground
8	Power

**2.1.5.3 Data Connection:**

The 9-pin female RS232 connector is used both as the modem serial interface and also to configure the intelligent processor board within the MiChroSat modem, the interface pin-out remains the same for both functions:

Data Connection 9 Way Female Connector	RS-232 Signal Name
Pin 1	DCD – Data Carrier Detect
<i>Pin 2</i>	<i>Rx – Receive Data</i>
<i>Pin 3</i>	<i>Tx – Transmit Data</i>
Pin 4	DTR – Data Terminal Ready
<i>Pin 5</i>	<i>GND – Signal Ground</i>
Pin 6	DSR – Data Set Ready
Pin 7	RTS – Ready to Send
Pin 8	CTS – Clear to Send
Pin 9	RI – Ring Indicator

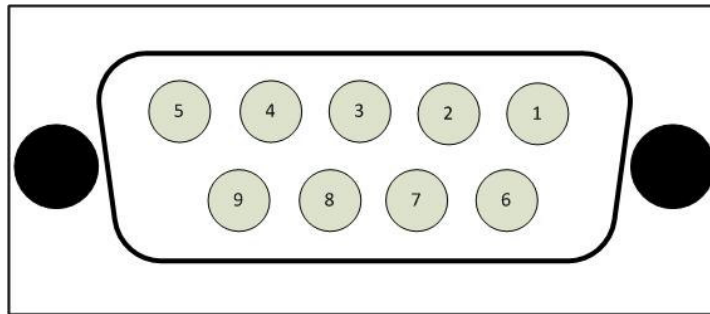

**MiChroSat 9 Way D-Type Female Pin Numbering**

Standard cable pin-outs for MiChroSat to PC (DTE – straight through cable) and MiChroSat to Application (DCE - cross over cable) cables are included in Appendix E.

In configuration mode a straight through cable is required from the PC running the MichroFace software to the MiChroSat modem (see section 7 for further information on the use of the MiChroFace controller configuration software).

**Three Wire RS232 Connection:**

The connections for 3 wire operation are indicated in *italic* text above.

**Note:** To operate the modem in 3 wire mode, the MiChroSat 2403 must first be programmed for 3 wire operation by sending AT&D0&K0 using a full 9-way RS232 cable. Only once the changes have been programmed, may a 3-wire cable be successfully connected. These commands may be programmed at modem power on utilizing the automatic initialization feature of the MiChroSat Modem.

### 2.1.6 Indicator LEDs

The MiChroSat 2403 has three external LEDs indicating status of modem operation.

**Program (Red)** – When illuminated this LED indicates the MiChroSat 2403 modem is in configuration mode, note this will also flash when switching between operation and configuration modes.

**Power (Amber)** – When illuminated the LED indicates that the satellite modem module within the MiChroSat is powered on, note that when the MiChroSat 2403 is in both programming mode and sleep mode, the modem is powered off, so the power LED will not be illuminated.

**Network (Green)** – When illuminated this LED indicates that the satellite modem module within the MiChroSat 2403 is receiving a satellite signal. Note that if this LED is not illuminated the MiChroSat modem will not be able to place or receive calls.

### 2.1.7 Program Mode Switch

The program mode switch located on the front panel of the MiChroSat 2403 is used to switch the MiChroSat 2403 unit between operating mode (where the device behaves as a modem) and configuration mode, where the data port is used to configure the intelligent processor board using the MiChroFace software.

(See section 7 of this manual for directions on the use of the MiChroFace software).

To toggle between operating mode and programming mode, the switch must be depressed for approximately 5 seconds, when a mode change is triggered the red program LED will flash briefly before changing mode, when program mode is operational the red LED will be illuminated constantly.

**Note:** When power cycled, the MiChroSat 2403 will always boot into operating mode.

**2.1.8 RF Interface Specifications**

General RF parameters are listed in the table below.

Parameter	Value
Frequency Range	1616 to 1626.5 MHz
Duplexing	Time Domain Duplex (TDD)
Osc. Stability	+/- 1.5 ppm
Input/output Impedance	50 ohms
Multiplex Method	TDMA/FDMA

**2.1.9 Antenna Specifications**

Wireless Innovation offers several types of antennae for use with the MiChroSat Modem.

The default antenna supplied is the AeroAntenna AT1621 fixed Mast Antenna, which is suitable for both fixed mount and marine applications:



AeroAntenna AT1621 Fixed Mount Antenna

Details of suitable alternative antenna solutions may be provided on request, however note that any antenna solution used with a MiChroSat 2403 modem must also be Iridium approved prior to operation on the Iridium network.

**2.1.10 Radio Characteristics**

The In-Band characteristics are for the MiChroSat 2403 are listed below:

Parameter	Value
Average power during a timeslot	7W (max)
Average power during a frame	0.6W (typical)
Receiver sensitivity at 50 ohm	118.5 dBm (typical)
Receiver spurious rejection at offsets > 1 MHz	60dB (typical)

The link Margin for the MiChroSat 2403 is given below:

Parameter	Value
Maximum Cable Loss	2.5dB
Link Margin	13.1 dB (free space)

**2.1.11 RF Cable Requirements**

The MiChroSat 2403 uses a single cable terminated with a standard Female TNC antenna connector for both transmit and receive, Cabling between the modem and the antenna is critical to ensure that a minimal amount of signal loss is achieved. The loss between the antenna and the modem must not exceed 2.5dB at the operating frequency of 1616 to 1626.5 MHz. Loss is attributable to several factors. These factors include number of connections, cable length, quality of cable, etc. The table below lists the losses and maximum distances a variety of commonly used cables (assuming a total connector loss of no more than 0.5dB):

Cable Type	Diameter (cm)	Loss dB/m	Max Length (m)	Max Length (ft)
LMR-195	0.5	0.48	5.00	16.00
LMR-240	0.61	0.33	7.50	24.50
LMR-400	1.03	0.17	14.50	46.00
LDF2-50	1.18	0.14	17.50	57.00
LDF4-50	1.60	0.090	27.50	90.00
LDF5-50	2.80	0.052	48.00	157.00

**Note:** The above table excludes losses incurred in any RF tails that may be required to connect modem/antenna.

For specific cable requirements please contact Wireless Innovation Ltd for further information.

### 2.1.12 Antenna Location

For effective operation of the MiChroSat 2403 modem it is essential that the antenna is deployed in a suitable location, the following section provides a series of guidelines for best practice in antenna installation.

**Note:** The MiChroSat modem and the antenna must be installed in a manner such that the "RF Safety Precautions" identified at the beginning of this manual are not violated during normal use by the operator or bystanders.

The Iridium system design is predicated upon line-of-sight access to the Satellite and due to the movement of these Satellites, it is very difficult to predict as to which part of the Sky the Satellites are located. Therefore the antenna MUST have a clear view to the satellite at ALL TIMES.

Obstructions to the line-of-sight can create areas of poor system coverage, These areas of poor coverage can decrease or possibly eliminate the user's ability to operate the MiChroSat modem with predictability.

All antenna and cable installations must take into account the following;

- Ensure that the antenna is mounted so that it will not become detached from its supporting structure under normal external forces.
- The antenna must be upright/facing the sky to ensure maximum exposure of and for the satellite.
- The antenna must be located so that it has a good view of the sky, ideally providing horizon to horizon coverage. For optimum coverage the satellite antenna should be deployed in a location where it has clear and un-interrupted view of the sky from 10 degrees above horizontal in all directions.
- The satellites fly in a South-North orbit so the antenna must not be mounted such that obstructions are or will occur in this plane.
- Mast Antenna should be mounted so that they are away from structures (masts, buildings, etc) by a minimum distance of at least 0.5metres.
- Puck/vehicle mount antennae should be mounted such that they have a good ground plane and will not cause interference to vehicle or its operator.
- Co-axial cable lengths should be minimised to prevent undue signal attenuation, as per the recommendations in paragraph 2.1.10 of this manual.
- Route the cable between the antenna and the MiChroSat modem so that the cable does not create an obstruction.
- Route and restrain the cables to prevent them from vibrating or moving under normal conditions, which could result in damage to the antenna, the MiChroSat modem or the coaxial cable connections.
- When you must bend a cable, avoid kinking it, and ensure that each bend radius follows the cable supplier's recommended limits.
- Use coaxial sealant, shrink wrap tubing, amalgamating tape, or another suitable product to seal all cable connections appropriately to prevent moisture and corrosion damage from weather exposure.
- Tighten the connectors according to the appropriate manufacturers' torque specifications.

**Note:** A bad connection may corrode, causing performance problems and potentially affecting warranty coverage of the MiChroSat modem.

The pictures below illustrate typical effective MiChroSat 2403 antenna installations:



**Typical Wall Mounted Installation**



**Water Reservoir Installation**



**Equipment Cabinet Mounting**



**Equipment Cabinet Mounting #2**

### 2.1.13 Analogue Audio Specifications

The analog audio interface is comprised of the analog audio input (microphone) and output (speaker) signals referenced to the 0V signal ground (unbalanced signalling).

Please note in order for the user to utilize these connections the modem must first be initialized correctly to switch on the audio capability (please refer to Appendix A for details). Note that the user will typically need to provide the amplification circuitry required for both the microphone and speaker lines.

The analogue input/output audio lines are presented on the RJ-45 voice interface as detailed in section 2.1.4.2, please contact Wireless Innovation for further information and support if your application requires directly interfacing to this port.

### 2.1.14 SIM Interface Specifications

The MiChroSat 2403 contains an integrated SIM reader located beneath a cover plate within the internal modem module. The MiChroSat modem requires a valid Iridium SIM card for operation.

### 2.1.15 Optional Power Management Facility

The MiChroSat 2403 modem may be automatically powered on/off via the onboard intelligent controller interface which is configured via the MiChroFace software (Please see section 7 for detailed instruction on the use of the Michroface programming software). The options that may be configured are set out below:

- Power up and Power down at pre-determined configurable times
- Power up and Power Down by sensing the state of RS232 control lines from the User Application.

In this option the DTR and RTS control lines can be monitored and provide an input to power up and down the internal modem. For 3 wire operation the User Tx line can be used.

- Always On Mode (No Power Saving)
- 24 periodic Shutdown

### 2.1.16 Environment Specifications

#### 2.1.16.1 Operating Temperature

Operates to specifications over a temperature range of -30° C to +60° C.

#### 2.1.16.2 Storage Temperature

May be stored to an extended temperature range of -40° C to +70° C.

#### 2.1.16.3 Operating Humidity

Relative Humidity of 25% -65% without external protection.

**2.1.17 Dimensions**

The outside dimensions are length 215mm width 170mm, and height 55mm. The full mechanical specifications are as below:

**Rear View - Dimensions**

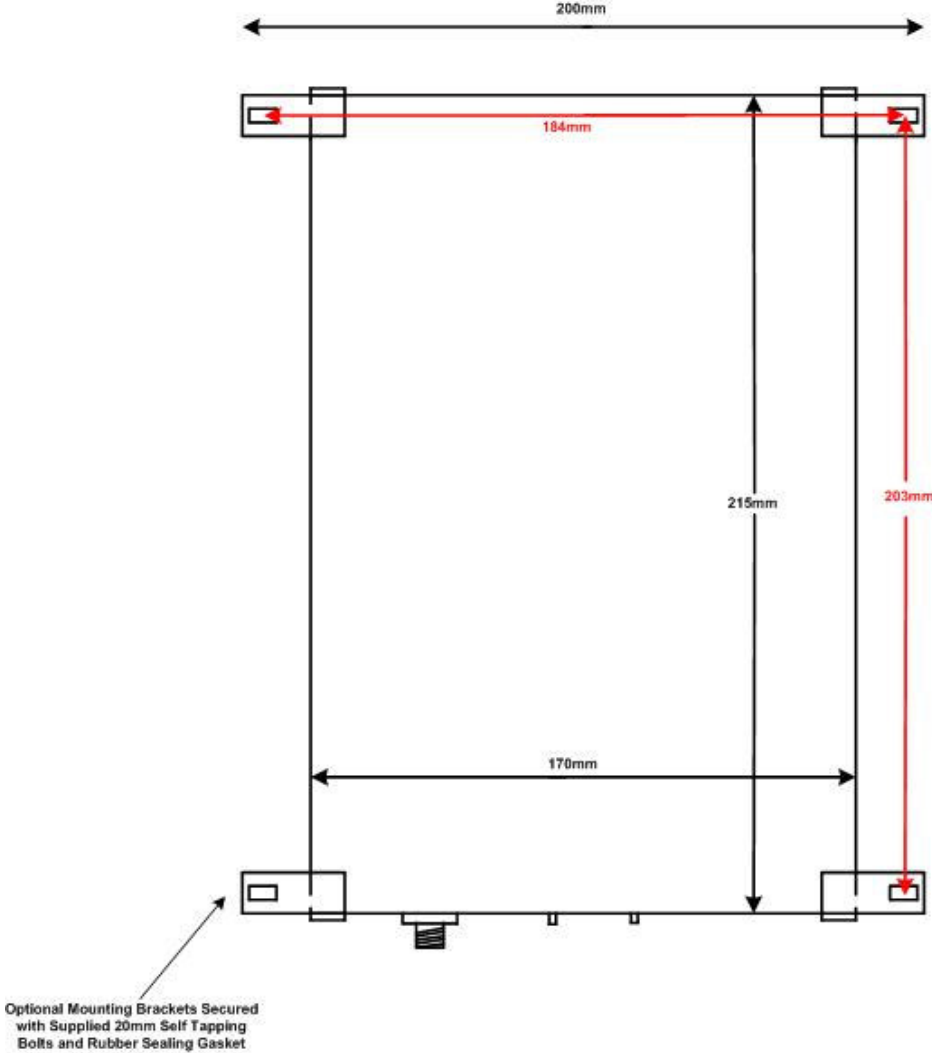

**Front View - Dimensions**

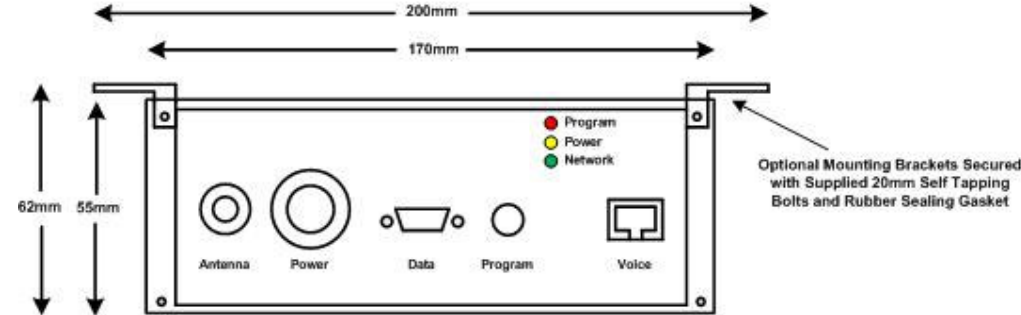

## 2.1.18 Installation Guidelines

### 2.1.18.1 *Hardware Mounting*

The MiChroSat 2403 is designed to be mounted either directly on a flat surface such as shelf or similar secured to a wall or back plate within a panel or enclosure.

To facilitate mounting the MiChroSat 2403 on a wall or back plate, a mounting kit is provided containing right angle mounting ears, sealing gaskets and 20mm bolts used to attach the mounting ears. Mounting the MiChroSat modem using this kit provided will not affect the IP-44 rating of the enclosure.

The diagram in section 2.1.17 includes the dimensions of MiChroSat 2403 with the mounting ears fitted and also provides the centre to centre dimensions of the mounting points.

**Note:** A Torx 10 screwdriver is required to remove the mounting bolts and fit the longer replacement bolts supplied within the mounting ears kit.

Although the MiChroSat 2403 is designed for deployment in harsh conditions, if the unit is to be deployed in an outdoor environment it is strongly recommended that the modem be installed within a secondary enclosure to provide full protection against all prevailing weather conditions. Note that in extreme environments, a passive solar shade or additional insulation may also be required to ensure that environmental operating conditions of the modem are not exceeded.

In addition secondary weatherproofing of all external enclosure connectors is recommended using self-amalgamating tape or similar weatherproofing sealant to ensure water ingress does not incur.

The images overleaf show a typical mounting scenario for the MiChroSat 2403, optional DPL phone handset and AC/DC PSU, ready for deployment in an outdoor environment. In this scenario, the MiChroSat2403 is deployed within a secondary GRP IP-65 enclosure to provide both weather and temperature protection. In addition, this type of mounting provides secondary weather protection of all connectors via the use of stuffing glands to seal cable entries.



**Typical enclosure suitable for deploying MiChroSat 2403 in an Outdoor Environment**

## Operational Considerations

### 2.2 RS-232 Three Wire Serial Operation

By default the MiChroSat 2403 modem is configured for nine wire RS-232 operation using hardware handshaking, however it may be configured for three wire operation (no hardware handshaking).

Unless the client application only supports three wire operation, it is normally recommended that full nine wire operation of the RS-232 port be utilized.

To operate the modem in three wire mode, the MiChroSat 2403 must first be programmed for three wire operation by sending AT&D0&K0 using a full nine-way RS232 cable. Once the changes have been programmed a three-wire cable may then be successfully connected. These commands may be programmed at power on utilizing the automatic initialization feature of the MiChroSat Modem or stored to the modem profiles using AT&W0&W1.

### 2.3 Setting RS232 Interface Rates

By default the MiChroSat 2403 is set to auto-baud to the Users RS232 port setting. This can be changed and configured to only use a user defined baud rate, this should be achieved by using the MiChroFace configuration program as detailed in Section 7 in this Manual, rather than through use of the AT+IPR command.

### 2.4 Setting the Modem to Auto Answer Incoming Data Call

The modem will answer an incoming data call if the S0 register is set to a non-zero value. If S0 is non-zero, it will answer the phone on the first ring. If S0 is zero, it will not answer any incoming calls.

The S0 register is set to 1 simply by issuing AT+S0=1.

### 2.5 Permanently Storing Configuration Settings

AT command settings can be permanently stored on the modem so that the settings remain persistent after a power cycle. The modem has two profiles in which it can store configuration settings, and the user/installer can configure which profile is loaded by default:

AT&Wn stores the present configuration in profile n, where n can be either 0 or 1.

AT&Yn designates which profile is loaded after reset or power-up, where n is either 0 or 1.

## 2.6 Short Message Service (SMS)

Wireless Innovation can provide mobile originated and terminated SMS as part of the standard service package. This provides the ability to send and receive SMS messages from or to another MiChroSat modem and also from modem to e-mail and vice versa, it also provides support send and receive SMS messages from many terrestrial GSM networks.

SMS messaging is controlled via AT commands, and messages are extracted over the serial port of the modem. Please refer to the Appendix A (AT Command Reference Document) and Appendix C (SMS Integrators Guide) for additional information on commands and assistance on the utilization and integration of SMS messaging.

**Note:** The MiChroSat 2403 currently supports SMS messages in PDU format only.

## 2.7 Short Burst Data

Wireless Innovation provides mobile originated and terminated Short Burst Data (SBD) messaging as part of its enhanced service offering. SBD provides the ability to send and receive small messages to/from another MiChroSat modem without the need to establish a circuit switched call. SBD also supports communication to external networks via E-mail and other interfaces.

SBD messaging is controlled via AT commands, with messages being extracted over the serial port of the modem. Refer to the Appendix A (AT Command Reference Document) for additional information on commands required to utilise this unique messaging service.

**Note:** SBD functionality is not provisioned on data only SIM cards as a standard feature, please contact Wireless Innovation Ltd for more information if SBD support is a requirement for your application.

## 2.8 Phone Numbers

All MiChroSat data subscribers have two phone numbers, a “*MSISDN*” for voice calls, and a “*MSISDN-C*” for data calls.

The following dialling rules apply:

- When placing a voice call to a MiChroSat modem, the caller **must** dial the ***MSISDN***.
- When placing a data call to a MiChroSat modem, the caller **must** dial the ***MSISDN-C***.

An example of the current numbering scheme as of 2008 is below:

The MSISDN number is given by 8816514\*\*\*\*\*

The MSISDN/C number is given by 8816937\*\*\*\*\*

Where:

8816 is Iridium International prefix

514 defines the voice number (MSISDN)

937 depicts a data number (MSISDN/C)

\*\*\*\*\* depicts the unique telephone number of MiChroSat modem.

**Note:** Voice call functionality is not automatically activated on data SIM cards (unless specified on order); please contact Wireless Innovation Ltd for more information if voice support is a requirement for your application.

## 2.9 Use of AT Commands with the MiChroSat Modem

All MiChroSat Modems provide support for Hayes compatible AT commands. In addition to the standard Hayes commands, extended command support is provided for some GSM specific commands and also for Iridium Network specific commands. Since the MiChroSat Modems are Hayes compatible, control and configuration is very similar to other PSTN/GSM modems in use today, this ensures that the MiChroSat modem is interoperable with most commonly used communications software/applications.

## 2.10 Modem Mode of Operation

Like any Hayes compatible modem, the modem functions in one of two modes, either command mode or data mode. When the modem is in command mode (also known as off-line mode), AT commands can be entered to control the modem. When in data mode (also known as on-line mode), the modem is connected to a remote system and any characters sent to it will be transmitted to the remote system. It is possible to enter the command mode without terminating the call by using the +++ escape sequence described in detail in Appendix A.

### 2.11 Command Entry

An AT command consists of a string of characters sent by the computer to the modem while in command mode. A command string has a prefix, a body, and a terminator. The prefix consists of the ASCII characters AT or at. The body is a string of commands restricted to printable ASCII characters. The default terminator is the <CR> character (carriage return). The following rules apply to the entry of commands:

1. All commands (apart from A/ and +++) start with AT or at. The commands in a command string (apart from A/ and +++) are executed only after the return or enter key is pressed.
2. Use either upper or lower case letters, not a combination.
3. The maximum number of characters in a command string is 128. Multiple commands can be concatenated onto a single command line or by a semicolon.
4. Command editing can usually be performed by the backspace or delete keys.
5. If a parameter is missed from a basic command, a zero is implied (e.g. ATH implies ATH0). If an optional parameter is skipped from an extended command, the current value is implied. Optional parameters are enclosed by square brackets ([...]) in this document.
6. Spaces can be entered into a command string to increase clarity. These are ignored.
7. Characters that precede the AT prefix are ignored.
8. Ctrl-x can be used to abort a command line input.

The structure of an AT command is illustrated below:

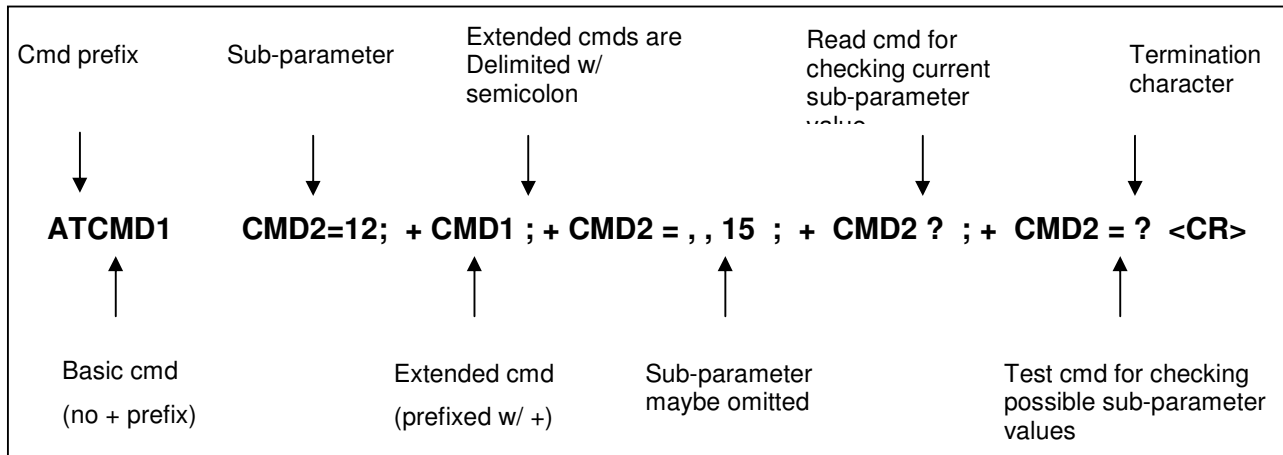

## 2.12 Modem Responses Codes

When an AT command is executed by the modem, a result code is sent back to the computer by the modem. In addition, a result code may also be spontaneously generated by the modem as result of other events such as an incoming call. In verbose mode of operation (enabled via the use of the ATV1 command), result codes are returned in the form of plain text strings.

Some common results codes are presented in the following table.

<b>Numeric Code</b>	<b>Verbose Code</b>	<b>Description</b>
0	OK	Command executed
4	ERROR	Command rejected
1	CONNECT	Connection established
3	NO CARRIER	Connection terminated
7	BUSY	Busy signal detected
8	NO ANSWER	No answer
2	RING	Incoming call received

Response codes may also be disabled using the ATQ0 command.

### 3 COMMONLY USED MODEM AT COMMANDS

The list below summarises the most commonly used “at” commands from user to the modem. Please refer to Appendix A for full list of ‘at’ commands and a more detailed explanation for each of the below.

#### **AT – Attention Code**

This is the prefix for all commands except A/ and +++. When entered on its own, the modem will respond with the OK results code.

#### **A/ – Repeat Last Command**

Repeat the last command issued to the modem unless the power was interrupted or the unit is reset. A/ is not followed by <CR>.

#### **+++ – Escape Sequence**

The escape sequence is used to transfer from data mode to command mode without disconnecting from the remote modem. After a pause, the modem will respond with OK. Register S2 can be used to alter the escape character from +, the factory default, to any hexadecimal value in the range 0 to 255.

#### **A – Answer**

Answer immediately. This causes the modem to answer the incoming call.

#### **D – Dial**

Dial a number. The dial command causes the modem to enter originate mode and act as an auto dialler for connection to other modems. The usual format of the command is **ATDnx..x** where n is a Dial Modifier and x is the number to be dialled. The following are valid numbers: 0123456789\*#;.

Dial modifiers are used to alter the manner in which the modem dials.

L Redial last number.

P Use pulse dialling (*No action, compatibility only*).

T Use tone dialling.

Any character received from the DTE during the call establishment phase will cause the call attempted to be terminated.

To establish a voice call the number to be dialled should be followed by a semi-colon.

#### **Hn – Hang-up**

Control the hook switch.

This command is used to clear a connection.

0 Place the modem on hook.

**+CBST – Select Bearer Service Type****Set Command: +CBST**

Select the bearer calls to **PSTN only**

AT+CBST=6,0,1

Or

AT+CBST=0,0,1

Select the bearer calls to **Iridium only**

AT+CBST=71,0,1

**Read Command: +CBST?**

Query the current bearer service type settings. Response is in the form:

+CBST: <speed>,<name>,<ce>

**S0=n – Auto Answer**

Assigning a value from 1 to 255 in register S0 tells the modem to automatically answer incoming calls after n rings, where n is in the range 0-255. The recommended setting is ATSO=1, which sets the modem to answer after one ring. The setting of 0 (ATSO=0) turns off the automatic answer feature.

**+CREG? – Registration Status**

This command returns the registration status of the modem.

If a modem has successfully registered response will be of the format 000,001.

**+CSQ – Signal Strength**

This command returns the signal strength of the modem.

Where range is 0 to 5. 5 is highest received signal strength.

The full AT command reference is provided in Appendix A.

## 4 CALL SCENARIOS

### 4.1 MiChroSat to MiChroSat Calls

#### 4.1.1 Configuring the Originating MiChroSat Modem

Using a suitable terminal emulation program, configure the serial port on the computer to a data rate between 600bps and 19,200bps with 8 data bits, no parity and one stop bit. Section 6.1 describes how to do this using HyperTerminal.

The originating modem should be configured to request the appropriate bearer service using the following AT command:

**AT+CBST=71,0,1<carriage return> (MiChroSat to MiChroSat only)**

The following AT command is used to dial the terminating modem:

**ATDT<phone number><carriage return>**

Where <phone number> is the data phone number (the MSISDN-C) of the terminating MiChroSat modem. For all calls the full international number must be dialed, therefore the number would be '+' or "00" followed by the MSISDN-C of the terminating user (e.g. +8816937012324).

After dialling has been initiated, a response code will be returned to indicate the status of the call (e.g., CONNECT, BUSY, NO ANSWER, NO CARRIER).

Assuming a connection is established (typically indicated by a response of CONNECT), both modems will then enter data mode and data exchange can occur between the modems.

To initiate a disconnect, the following character sequence is sent to the modem in order to cause it to return to the command mode:

+++

Once the modem has returned to the command mode, the following Hayes AT command is used to disconnect the call:

**ATH<carriage return>**

#### 4.1.2 Configuring the Terminating MiChroSat Modem

Using a suitable terminal emulation program, configure the serial port on the computer to a data rate between 600bps and 19,200bps with 8 data bits, no parity and one stop bit. Section 6.3 describes how to do this using HyperTerminal.

The originating modem should be configured to request the appropriate bearer service using the following AT command:

**AT+CBST=71,0,1<carriage return> (MiChroSat to MiChroSat only)**

The terminating MiChroSat modem can be configured to automatically answer when an incoming call is received. This is accomplished using the following standard Hayes AT command:

**ATS0=<N><carriage return>**

Where <N> is an integer that corresponds to the number of rings that occur before the call is answered. In general, it is recommended to use a value of 1 for this (i.e. ATS0=1).

When an incoming call is received, a **RING** response code is presented, the terminating modem will then automatically answer the call once modem negotiation is completed a response code will be returned to indicate the status of the call (e.g., CONNECT, NO CARRIER). Assuming a

connection is established (typically indicated by a response of CONNECT), both modems will then enter data mode and data exchange can occur between the modems.

To initiate a disconnect, the following character sequence is sent to the modem in order to cause it to return to the command mode:

**+++**

Once the modem has returned to the command mode, the following Hayes AT command is used to disconnect the call:

**ATH<carriage return>**

## 4.2 MiChroSat to PSTN Calls

NOTE: Connectivity via PSTN is not generally recommended, prior to attempting to utilize communications via PSTN please read the recommendations in section 1.1.1 of this manual.

### 4.2.1 Configuring an Originating MiChroSat Modem (Calling to PSTN)

Using a suitable terminal emulation program, configure the serial port on the computer to a data rate between 600bps and 19,200bps with 8 data bits, no parity and one stop bit. Section 6.1 describes how to do this using HyperTerminal.

The originating modem should be configured to request the appropriate bearer service using the following AT command:

**AT+CBST=6,0,1<carriage return> (MiChroSat to PSTN)**

**OR**

**AT+CBST=0,0,1<carriage return> (MiChroSat to PSTN - Autobaud)**

The following AT command is used to dial the terminating modem:

**ATDT<phone number><carriage return>**

Where <phone number> is the data phone of the PSTN modem to be dialled, the number must be entered in full international format including the correct country code (e.g. 00441594861887).

After dialling has been initiated, a response code will be returned to indicate the status of the call (e.g., CONNECT, BUSY, NO ANSWER, NO CARRIER).

Assuming a connection is established (indicated by a response of CONNECT), both modems will then enter data mode and data exchange can occur between the modems.

To initiate a disconnect, the following character sequence is sent to the modem in order to cause it to return to the command mode:

**+++**

Once the modem has returned to the command mode, the following Hayes AT command is used to disconnect the call:

**ATH<carriage return>**

#### 4.2.2 Configuring a Terminating MiChroSat Modem (Called From PSTN)

Using a suitable terminal emulation program, configure the serial port on the computer to a data rate between 600bps and 19,200bps with 8 data bits, no parity and one stop bit. Section 6.3 describes how to do this using HyperTerminal (Section 6.2 is an example of how to set up a PSTN modem using HyperTerminal).

The originating modem should be configured to request the appropriate bearer service using the following AT command:

**AT+CBST=6,0,1<carriage return> (MiChroSat to PSTN)**

**OR**

**AT+CBST=0,0,1<carriage return> (MiChroSat to PSTN - Autobaud)**

The terminating MiChroSat modem can be configured to automatically answer when an incoming call is received. This is accomplished using the following standard Hayes AT command:

**ATS0=<N><carriage return>**

Where <N> is an integer that corresponds to the number of rings that occur before the call is answered. In general, it is recommended to use a value of 1 for this (i.e. ATS0=1).

When an incoming call is received, a **RING** response code is presented, the terminating modem will then automatically answer the call once modem negotiation is completed a response code will be returned to indicate the status of the call (e.g., CONNECT, NO CARRIER). Assuming a connection is established (typically indicated by a response of CONNECT), both modems will then enter data mode and data exchange can occur between the modems.

To initiate a disconnect, the following character sequence is sent to the modem in order to cause it to return to the command mode:

**+++**

Once the modem has returned to the command mode, the following Hayes AT command is used to disconnect the call:

**ATH<carriage return>**

## 5 HYPERTERMINAL CONFIGURATION

HyperTerminal is an example of a popular terminal emulation application. Such applications provide the user with a terminal interface to interact and control a modem. In addition, they typically provide a basic mechanism to transfer data.

Hyperterminal is a free terminal emulation application that is provided as a part of all standard Microsoft XP Windows distributions, it is not however bundled with Vista/Windows 7 distributions., however it is downloadable as an additional application for these distributions. For convenience a link to download the latest release is provided via the MiChroSat website .

This section provides examples for configuring and using the Hyperterminal application for MiChroSat data calls. Please refer to Hyperterminal's help facility for further details with regard to the more generic aspects of usage.

### 5.1 Originating Calls from a MiChroSat Modem

1. When you first start the HyperTerminal application, you will be presented with the *Connection Description* window. Enter a name for the connection (Test has been used in the example below). Then click OK.



2. In the *Connect using* box, select the *COMn* or *Direct to COMn* option, where COMn designates the serial port used to communicate with the modem (COM1 in the example shown below). Click OK.

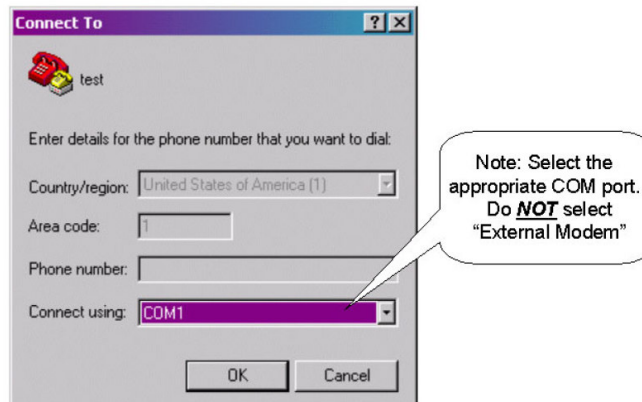

3. Configure the port settings as shown below, Click OK.

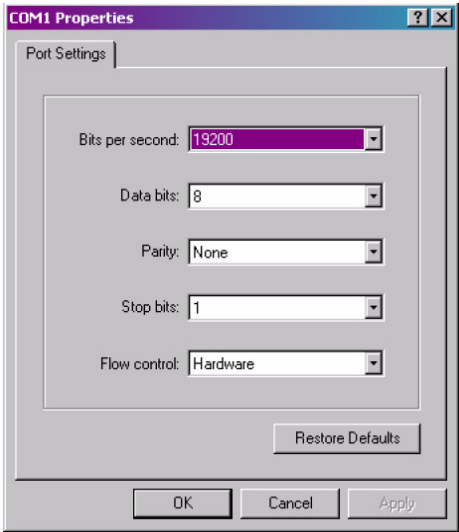

- 4. You will be presented with a terminal window and AT commands may then be entered. In the example below, the user enters an initial command to verify that the interface is working, sets the bearer service, dials a remote modem, connects, transfers some data and disconnects. (NOTE: The dialled number below is an example only, you must substitute your desired terminating modem number).

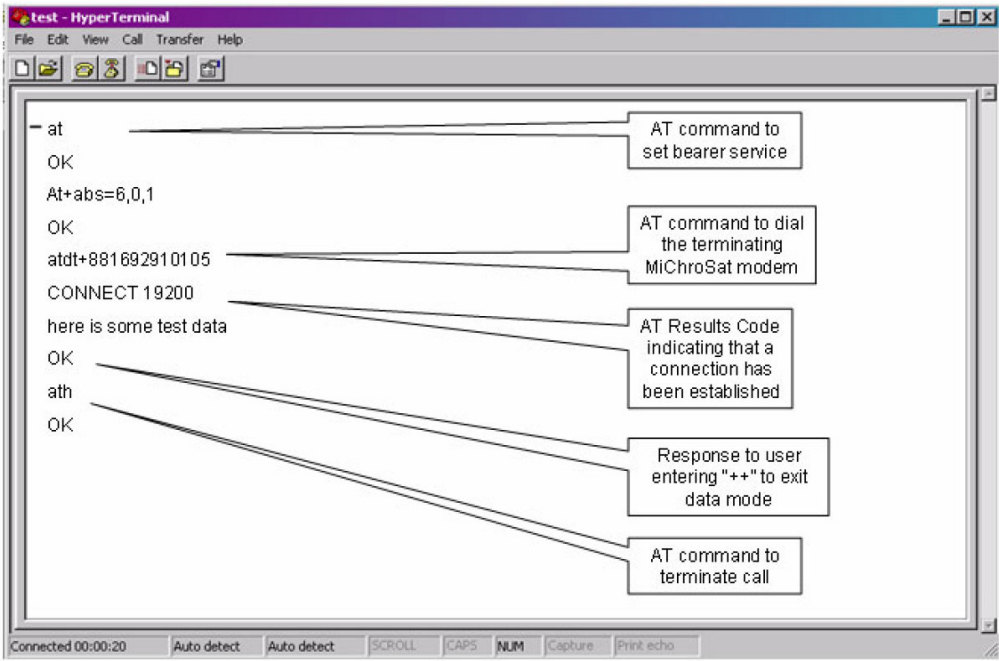

**5.2 Originating Calls from a PSTN Modem**

1. When you first start the HyperTerminal application, you will be presented with the *Connection Description* window. Enter a name for the connection ("Test" has been used in the example shown below). Click OK.



2. In the *Phone Number* box, enter the **MISDN-C** of the modem to be called, (The dialled number below is an example only, you must substitute your desired terminating MiChroSat modem number). In the *Connect using* box, select the PSTN modem you will be using to make the call. Click OK.

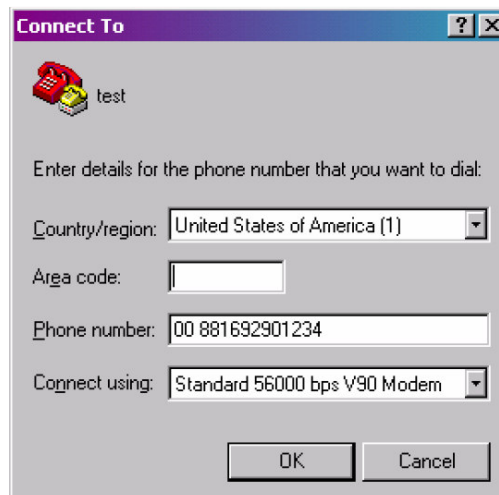

3. Click *Modify*.

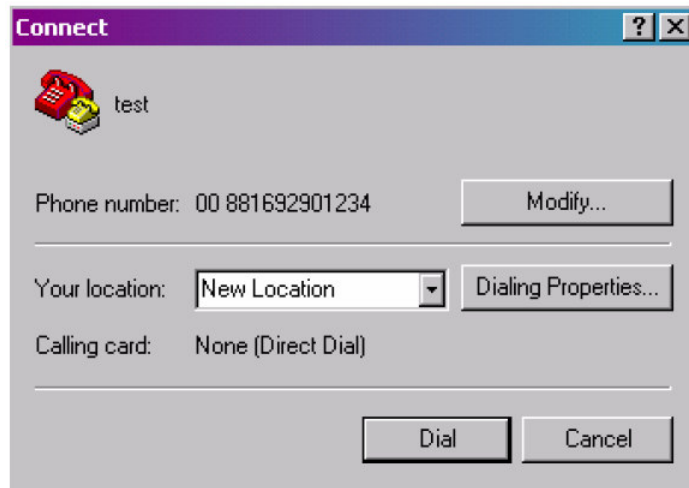

4. Make sure the *Use country/region code* and *Area code* is not checked. Click OK.

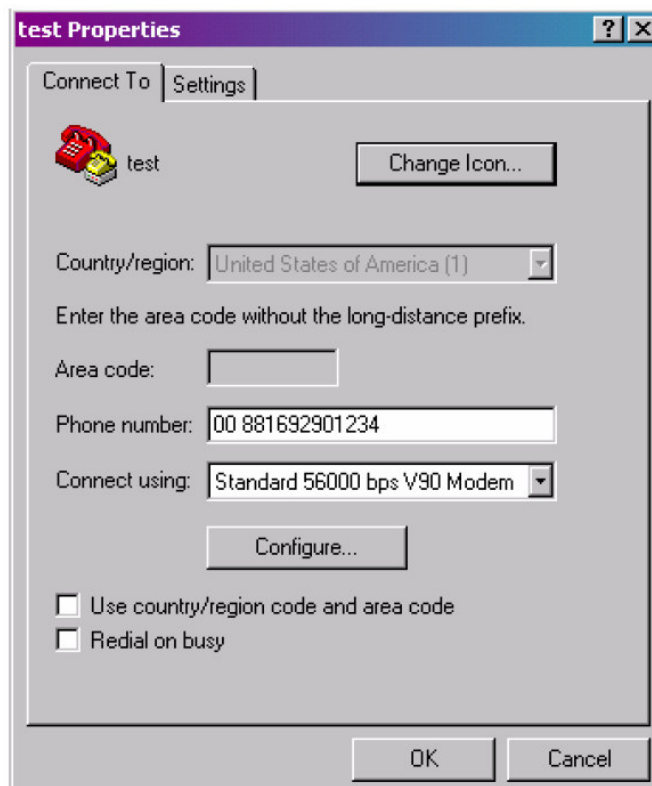

5. Click *Dial*.

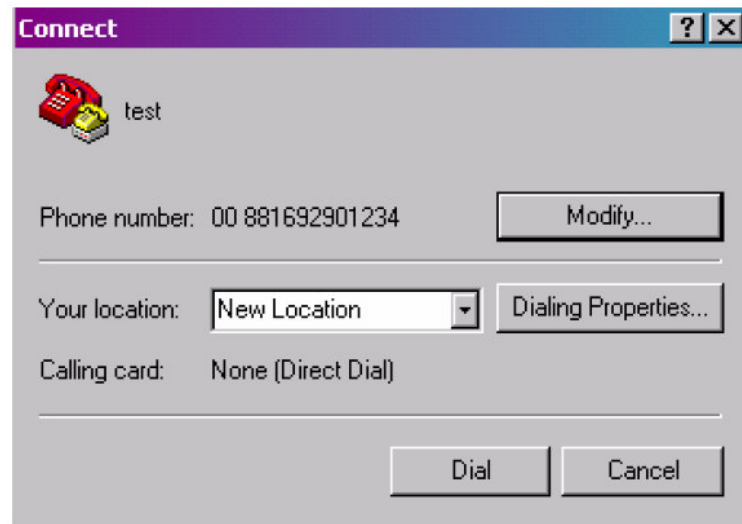

6. Once the modem has connected, you will be presented a terminal window and the modem will be in data mode as shown below, in this example the modem has just received some application data and then the user has entered control mode, and sent ATH to drop the call.

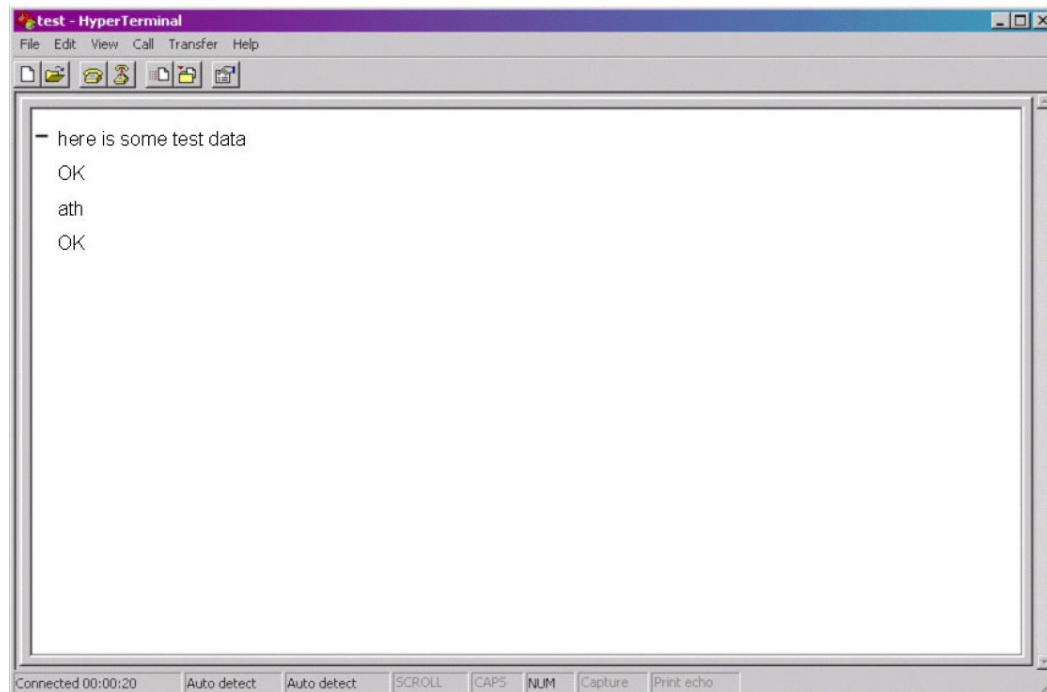

### 5.3 Configuring a MiChroSat Modem as the Terminating Modem

1. When you first start the HyperTerminal application you will be presented with the *Connection Description* window. Enter a name for the connection (“Test” has been used in the example below). Click OK.

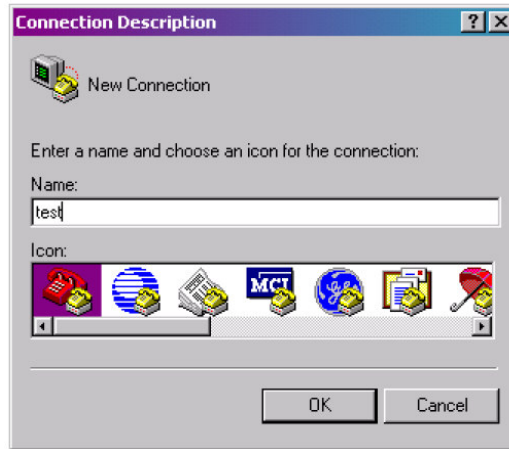

2. In the *Connect Using* box, select the *COMn* or *Direct to COMn* option, where COMn refers to the serial port used to communicate with the MiChroSat modem (COM1 in the example shown below). Click OK.

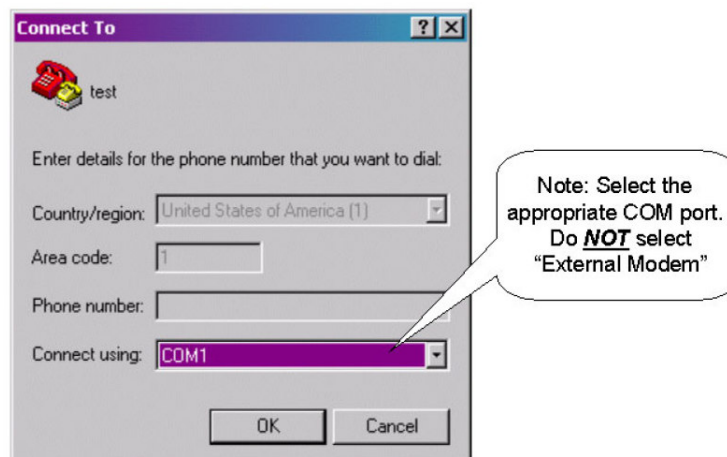

3. Configure the port settings as shown below. Click OK.

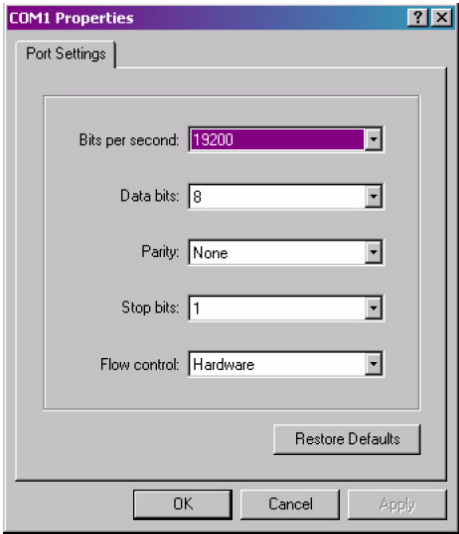

- 4. You will be presented with a terminal Window, the user should then enter the ATSO=1 command to enable the waiting modem to auto answer the call. In the example below, the user enables auto answer, receives an incoming call, successfully connects, the user then issues +++ ATH to enter command mode and drop the call.

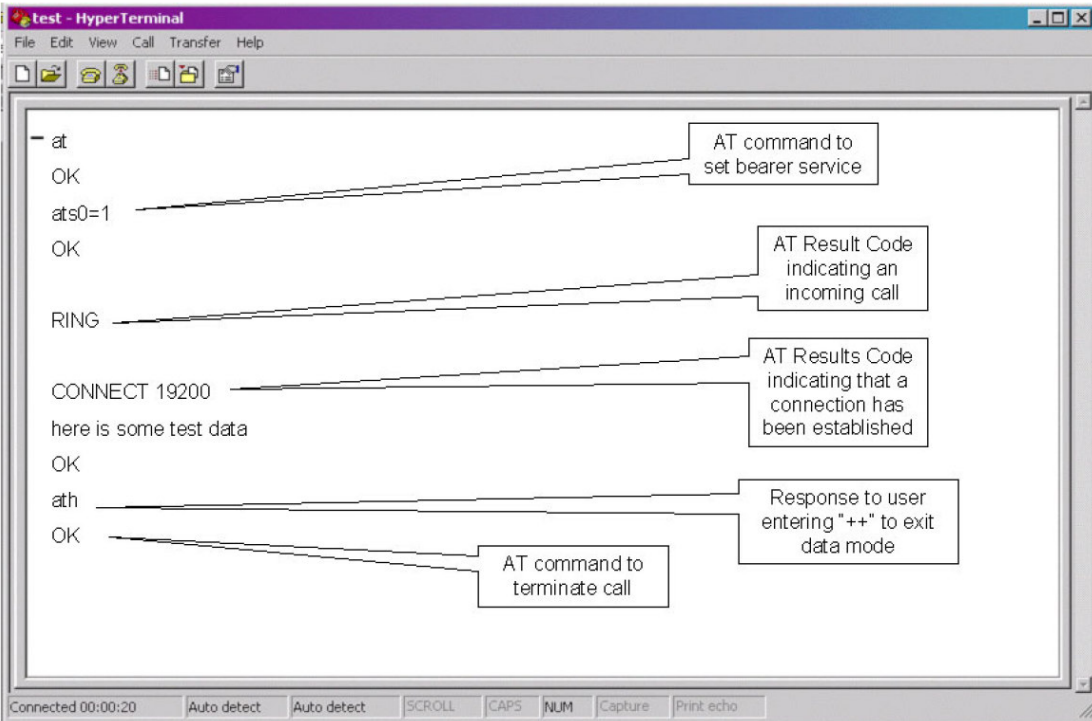

## 6 MICHROSAT CONTROLLER CONFIGURATION GUIDE

### 6.1 Controller description

The main function of the MiChroSat Controller is to provide an intelligent interface for the MiChroSat 2403. It provides control functionality to allow the powering up/down of the internal modem in applications that require low power consumption such as remote rural sites where battery or solar power sources are used.

The Controller can also be used to initialise the modem correctly to match the requirements of the customer application to allow use with standalone devices such as data-loggers. The Controller circuitry also provides isolation between the application RS232 interface and the modem interface.

Prior to use, the MiChroSat Controller must be configured using the MiChroFace configuration software to operate in the required manner:

This section will discuss in detail the procedures for configuring the software in the 4 modes of power saving operation:

- Mode 1: Modem Permanently Powered – No Power Saving Mode of Operation
- Mode 2: 24 Periodic Shutdown – Modem set to reboot every 24 hrs.
- Mode 3a: Preconfigured Timed Interval Window – Through the setting of an internal Real Time Clock the modem can be configured to power up and power down at user defined times.
- Mode3b: External/Application RS232 Interrupt – The Controller may be set to sense the state of a RS232 control line from the User Application to power up and power down the modem when the application wishes to communicate with the modem.

*Note: Power up window needs to be sett*

## 6.2 User Configurable Software - MiChroFace

This section describes the procedure to install and setup the MiChroFace software, and provides a functional description of each parameter required to setup the MiChroSat Controller.

Please note that prior to launching the software; the user must first connect the MiChroSat 2403 Multi-function RS232 port to that of the RS-232 port on the User PC.

### 6.2.1 Minimum PC requirements

1Ghz Windows Based PC – with at least one available RS-232 interface port.

**Note:** if a USB to RS-232 convertor is to be used, then FULL RS-232 replication is required.

512Mb RAM

25MB free hard drive space

CD-ROM

Supported Operating Systems: Windows™ XP/Vista/7 – 32bit Edition.

### 6.2.2 Installation

Insert the CD containing the MiChroFace software into the CD-ROM drive of the PC, under normal circumstances the installation manger should start automatically, if this does not occur, the user should browse to their CD-ROM drive using 'My Computer' or similar and run the Autorun.exe file manually.

Once the installation package is launched, the menu shown overleaf should be displayed:

**Note:** It is recommended that the user un-install any previous versions of MiChroFace prior to installing a new version.

It is recommended that users visit the MiChroSat website [www.MiChroSat.com](http://www.MiChroSat.com) to ensure that they have the latest version of MiChroFace prior to commencing installation.



From the menu options, select the 'Install MiChroFace' button, this will launch the installer application and guide the user through the installation process.

To complete the installation follow the on screen prompts as directed.

The you may then quit the install CD application by selecting the Exit button.

### 6.2.3 General Screen Layout



Once the application has started, the initial screen of the MiChroFace Configuration is displayed (qs above). The Software will then automatically search the available User’s PC Com ports to find which one is connected to the MiChroSat 2403, via the provided configuration cable.

Once the MiChroFace software has detected the MiChroSat 2403, the Com port background colour will change to green and show the com port number it is connected to. The Internal MiChroSat Controller’s Serial Number and also the controller firmware version will be reported at the bottom of the window (as shown above). For all other parameter settings, these will remain yellow until they have been successfully read from MiChroSat Controller.

The Current configuration can be Read by pressing each individual Read Button adjacent to each parameter or the User can ask for a Global Read from the Pull Down Menu at the top of the Window by selecting PIC – Read to which all Current Values for each parameter will be displayed.

If the MiChroFace software cannot detect an attached MiChroSat Controller, it will return Error in the status window and state that the MiChroSat Controller could not found in the Serial Number section at the bottom of the screen.

Once connected, the parameters may be updated using two different methods:

- a) By pressing the Update Controller button of each individual section, or
- b) Via the PIC pull down menu at the top left hand side of the Configuration Program – Select Update. A predefined configuration can then be selected and sent to the MiChroSat Controller.

If any of the parameter settings have been changed they will need to be sent to the MiChroSat Controller.

Once the parameters have been successfully updated (using either method), the background colour for each updated parameter will change to green.

**Note:** Only those data entries which have been correctly updated will display a green background.

Once all parameters have been successfully configured, the parameters can be saved to file for future use, with a user defined filename. These files can then be used to simplify future configuration downloading to the Controller. These are accessed from the file menu save/open functions.

### 6.2.4 Configuring Power Saving Modes

#### 6.2.4.1 Mode 1: Modem Permanently Powered – No Power Saving mode of operation

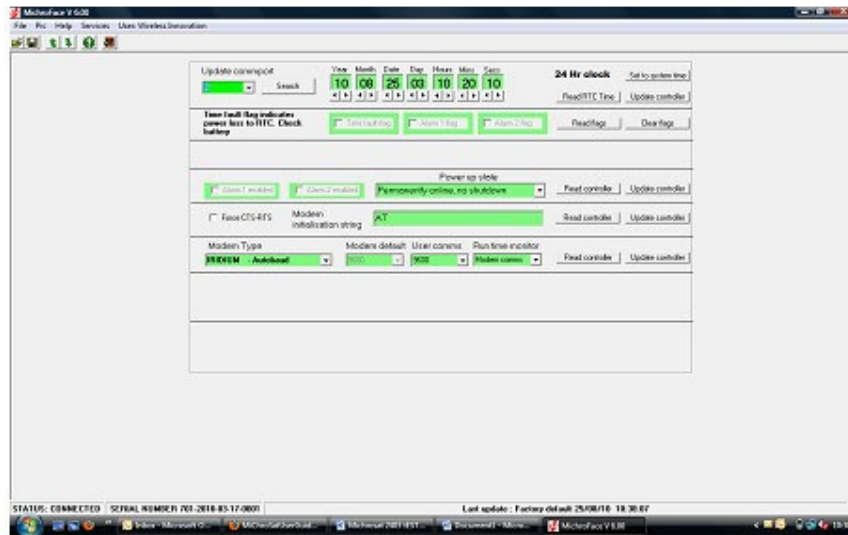

No power-saving options are used in this mode of operation. The function of the Controller is simply to initialise the modem correctly and set the baud rate of modem to that used by required application.

**Note:** The initialisation string should not include the “AT+IPR=n” (set baud rate command), the modem interface rates should only be configured using the MiChroFace software with the user interface rate set using the appropriate ‘user comms’ option with the user interface. This can be achieved by selecting the correct option under the Modem Type pull down menu as seen above.

In this mode of operation on power up, the Controller ensures the MiChroSat 2403 is operating correctly and initializes the modem. Following this the control of the modem RS232 lines are passed across to the application interface.

To use this mode of operation the user should configure:

1) The onboard Real Time Clock (RTC), this can either be set using the arrows underneath each time digit or by using the 'Set to system Time'. By selecting Set to system Time the RTC will automatically be set and turn green

2) The "Power up state", using the pull down menu – select "Permanently online, no shutdown"

3) The correct initialisation string, for operation of the modem for the unique application (please refer to Appendix A for full AT Command Specification). Note: The initialisation string has a limit of 70 characters

4) The application interface rate. Select 'Iridium Autobaud' from the modem drop down menu, then from the "User Comms" drop down menu, select the required interface data rate for application.

5) Press the Update Controller Button for each section to write the commands to the Controller, or perform a whole configuration upload as described in Section 7.2.5.2.

**Note:** if the application requires 3-wire RS232 mode of operation (i.e. no flow control) the user must also enable the Force CTS-RTS option by ticking the box in Communication Control, and update the Controller.

**6.2.4.2 Mode 2: 24 Periodic Shutdown – Modem set to reboot every 24 hrs**



In this mode of operation the main function of the Controller is to reset the power to the MiChroSat 2403 every 24 hrs, once per week or once per month, this method of operation ensures that the modem is correctly configured and forces the modem to re-register on the satellite network every day. At every re-start the internal modem is also initialized correctly and the required application baud rate set.

**Note:** For applications where the modem is always powered, this is the recommended power settings mode for the MiChroSat Controller.

In this mode of operation the user configures:

- 1) The onboard Real Time Clock (RTC), this can either be set using the arrows underneath each time digit or by using the 'Set to system Time'.
- 2) The "Power up state", using the pull down menu. – select "System permanently online, reboot on request" - The Alarm 1 (time for daily reset) section will then appear, when this option is selected.
- 4) The Alarm 1 operation (Reset Time), using the drop down options, select once per day to specify the frequency at which the modem will be reset.
- 5) The required time for the daily reset, (Hours and Minutes using 24 Hour Clock) - configure using the arrows provided.
- 6) The required initialisation string. For operation of the modem for the unique application (please refer to Appendix A for full AT Command Specification). Note: the initialisation string has a limit of 70 characters
- 7) The application interface rate. Select 'Iridium Autobaud' from the modem drop down menu, then from the "User Comms" drop down menu, select the required interface data rate for application. The "Run time monitor" option **must** be set to Modem Comms.
- 8) Press the Update Controller Button for each section, or perform a whole configuration upload as described in Section 7.2.5.2.

At the configured reset time the Controller will check the modem RS-232 transmit line to ensure that there is no data being communicated, if there is no communication, the Controller then waits 30 seconds and checks the transmit line again. If there is still no data being transmitted by the modem then the Controller will assume there is no active call and will reset power and re-initialise the modem.

This wait function is used to ensure that the modem does not power down if the modem is in use. The process will continue to cycle until the modem communications is idle before performing a reset.

**Note:** if the application requires 3-wire RS232 mode of operation (i.e. no flow control) the user must also enable the Force CTS-RTS option by ticking the box in Communication Control, and update the Controller.

**6.2.4.3 Mode 3a: Power Saving Mode - Preset Time Interval Window.**



In this mode of operation the User may set a “time window” during which the internal Controller will automatically ‘wake-up’ the modem. The main advantage of this time window is so that the MiChroSat 2403 can be called by another User device during this pre-defined time and powered down at all other times to conserve power. Each time the MiChroSat Controller powers up the modem, it will automatically be configured with the correct initialization string and the RS232 interface rate set.

It should be noted that the modem is powered down during low-power operation and in this state it was not answer an incoming call.

To operate in this mode, the user must configure:

- 1) The onboard Real Time Clock (RTC), this can either be set using the arrows underneath each time digit or by using the ‘Set to system Time’.
- 2) The “Power up state”, using the pull down menu. – select “intermittent online, preset time window” -The Alarm 1 (Power up time) and Alarm2 (Power down time) options will automatically appear.
- 3) The Alarm1 section, from the Alarm Operation pull-down menu, select “once per day/week/month”,
- 4) The required time for powering up of modem (hours and minutes – 24 Hour Clock).
- 5) The Alarm2 section, from the Alarm Operation pull-down menu, “select once per day”,
- 6) The required time for powering down of modem (hours and minutes – 24 Hour Clock).
- 7) The required initialisation string for operation of the modem for the unique application (please refer to Appendix A for full AT Command Specification).
- 8) The application baud rate. From the Modem default and User comms menus select required baud rate for application (up to maximum of 19200bps), select ‘Iridium- user setup’ in the Modem Type drop down options. The Run Time Monitor option **must** be set to Modem Comms.
- 9) Press the Update Controller Button for each section, or perform a whole configuration upload as described in Section 7.2.5.2.

It is also possible to set the Controller to wake the modem on a weekly or month basis, in these scenarios the user must also select the week day/date that they wish the power on window to occur.

At the configured Alarm 1 time, the Controller will power up the modem and initialise the modem correctly with the pre-configured values. At the configured Alarm 2 time, the Controller will check the modem RS-232 transmit line to ensure that there is no data being communicated, if there is no communication, the Controller then waits 90 seconds and checks the transmit line again. If there is still no data being transmitted by the modem, then the Controller will power down the modem and return to low power sleep mode.

This wait function is to ensure that the modem does not power down if the modem is in use, the process will continue to cycle until the modem is idle before performing a reset. The Controller will check to ensure that there is no data being communicated at that time from the modem to the application. If there is no communication the Controller then waits a further 90 seconds, if there is still no data being transmitted by the modem then the Controller assumes there is no active call and powers the modem down.

**Note:** The window function is designed to be used in situations where the MiChroSat 2403 is permanently connected to the power source, with the modem Controller board controlling power saving operation.

If power is not applied to the MiChroSat 2403 at the pre-programmed Alarm 1 'power up' time, the modem will not wake up during that window period, even if power is subsequently re-applied to the modem at a later point during that 'power up' window period (i.e. between the time period Alarm 1 to Alarm 2). In this scenario the modem will remain in sleep mode until the next programmed Alarm 1 power up time.

**6.2.4.4 Mode 3b: Power Saving Mode - External/Application RS232 Interrupt**

In addition to the setting of the time window to conserve power (Section 7.2.4.3) the user may also control the power up/down of the MiChroSat Controller through the sensing of one of the RS-232 Control lines from the application.

The advantage of this is to allow for the powering up and down of the modem within the control of a locally connected application.

Many applications (e.g. Telemetry RTUs and Dataloggers) have their own onboard power saving features and as part of a sleep mode, close down their RS-232 serial port when not in use to conserve power. When the application wishes to communicate with the MiChroSat 2403 they simply power up their RS-232 serial port thus enabling the RS232 Control lines (if present in cabling).

The MiChroSat Controller can be configured to power up the internal modem when the locally attached low power application wishes to communicate. The MiChroSat Controller can be configured to monitor two RS-232 control lines (DTR and RTS), the Controller can also monitor the application transmit line (Tx) if these control lines are not present (typically used with applications using 3 wire RS-232 communications).

To utilize this functionality the relevant switch has to be enabled/disabled on the internal MiChroSat Controller PCB as shown below:

**Warning:** Isolate power supply from the MiChroSat 2403 before removing cover.

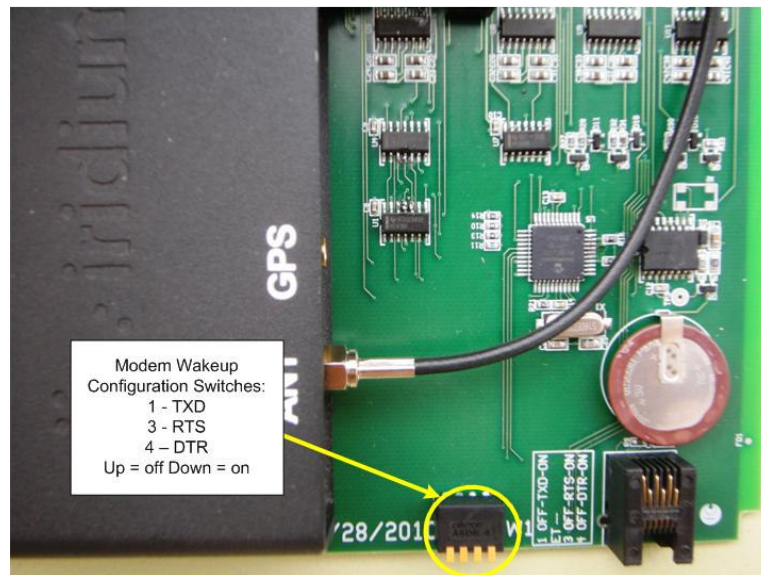

The External Interrupts :are enabled (switched on) and disabled (switched off) independently of each other. Only one of these interrupts should be used at any one time. The Interrupts are as follows:

- Switch 4 - for DTR External Application Interrupt
- Switch 3 - for RTS External Application Interrupt
- Switch 2 – not currently used (for future usage)
- Switch 1 – for TxD External Application Interrupt (in 3 wire mode scenario)

When either the DTR or RTS signal interrupt switch is enabled, the Controller board will then sense the signal levels received from the application on these RS-232 control lines. If the signal is asserted by the application then the Controller board will power up and initialize the modem, When the Control Line is de-asserted, following successful communication by the attached application, then the Controller will power down the modem approximately 30 seconds after any data transmission ceases.

If the application wishes to communicate with the modem again, then the application must re-assert the correct RS-232 control signal once more and the process is repeated. If the signal is not re-asserted then the modem will remain in the powered down state.

When the RS-232 TX signal interrupt switch is enabled, the Controller board will simply monitor the transmit line for any data transmitted from the application, When data is detected the Controller board will power up and initialize the modem, the Controller will then continue to monitor the application RS-232 Tx line for further data transmissions, if the Controller detects no RS-232 transmissions from the application for a period of 90 seconds, it will deem that communications has ceased and will then power down the MiChroSat modem.

**Note:** This interrupt mode of operation should only be used if the application has the capability of communicating via the RS232 port in three wire mode only, under normal operation the RS-232 control lines should be used to control the power state of the modem.

This functionality may be used in conjunction with the pre-set time window, to ensure minimum power consumption by the MiChroSat modem in power budget sensitive scenarios.

**Note:** The User should note that if the external interrupt line is enabled and that line is ALWAYS asserted, then the power to the internal modem will not be disconnected.

#### **6.2.4.5 Call Enable Function**

The call enable function is specifically provided for use in application where the MiChroSat 2403 modem will only ever receive incoming calls (will never place outbound calls) such as when connected to a basic data-logger or similar device.

When enabled, this function will force the modem to attempt place a call every time the modem is reset or powered on. This function can be configured to dial a non-routable number (12345678 for example) during part of the initialization process during each boot or reset cycle.

The use of this function during the boot process ensures that for modem registration and location information stored will be refreshed such that it remains up-to date within the Iridium gateway.

## 6.2.5 Michroface - Menu Pull Down Options

The menu items at the top of the screen operate in the same manner as standard Windows menus. These are tailored to suit the functionality of the programming software.

The following functions are available from the menu items at the top of the main programming screen.

### 6.2.5.1 FILE menu

#### OPEN

This allows the user to retrieve data files containing a set of previously saved parameters. These files contain data for all parameters used by the Controller and associated software.

#### SAVE

This allows the user to retrieve data files containing a set of previously saved parameters. These files contain data for all parameters used by the Controller and associated software.

#### QUIT

This function closes down the software package. **NB: All unsaved data is lost.**

### 6.2.5.2 PIC menu

#### READ

This allows the user to retrieve data from the Controller. The Controller is automatically placed in programming mode by the programming cable (Note that a specific MiChroSat Configuration cable must be used). Data may be saved to a file for future use.

#### UPDATE

This allows the user to download all preset parameters to the Controller, from the PC. Data may be entered manually, or from a stored file. Real time data is not stored – the pc time is instead entered into software.

### 6.2.5.3 HELP menu

#### ABOUT

Displays the version data for the software.

#### HELP

This function accesses a standard Windows help file system. Selection of section required is from a contents file/window. Click on the book icon for the section required, then select the appropriate page from the subject listing beneath this.

#### MANUALS

This function allows the user to access manuals for the MiChroSat 2403 Modem and Michroface configuration software.

## 6.2.6 Glossary of Parameters Used within Configuration Software

### Alarm 1 enable

If selected, enables alarm 1 for use with operating modes 1 and 2.

### Alarm 1 flag

This flag is set by the real time clock when the real time setting matches the alarm1 time settings defined by alarm 1 operating mode.

### Alarm 1 operation

Drop down menu allows selection of time of month, day, hour, minutes when alarm 1 activates when set in conjunction with alarm 1 time settings.

**Alarm 1 time setting**

This refers to the alarm 1 time setting which may indicate either of two actions depending on operation mode selected.

1. Intermittent mode – Denotes start of operation window.
2. Re-boot at preset time mode – denotes time for system re-boot.

**Alarm 2 enable**

If selected, enables alarm 2 for use with operating mode 1.

**Alarm 2 flag**

This flag is set by the real time clock when setting matches the alarm2 time settings defined by alarm 1 operating mode.

**Alarm 2 operation**

Drop down menu allows selection of time of month, day, hours that alarm 2 activates.

**Alarm 2 time setting**

Only used in intermittent mode. Denotes end of operation window.

**Clock time**

This refers to the real time setting of the RTC Controller. This only updates on screen at user read request. This may be set to PC system time or any time manually.

**Force CTS-RTS**

If selected, asserts an internal loop back on the CTS/RTS signalling back to the modem during run time operation, constantly asserting RTS – Recommended for 3 wire mode serial operation of the modem.

**Modem default**

Defines the default power up baud rate of the modem – by default this is set to 19200 bps

**Power up state**

Selects the operating mode of the Controller

1. Permanently online – no shutdown
2. System permanently online, reboot on request
3. Intermittent online, pre-set time window

**Run time monitor**

Allows selection of which data transmit line the Controller will monitor, user or modem, for shut down in low power/power cycle modes. Default – user comms

**Time fault flag**

This flag is set when a power failure to the real time clock occurs. The real time clock settings are lost. The real time clock will start from an all zero setting and count on from there.

Note that these flags do not automatically display clock and alarm status. The Controller must be re-read to obtain this.

### Update comport

This function displays all available comports on the PC, allowing the user to select any available comport that is connected to the MiChroSat Enclosure via the included Configuration cable. **Note:** The software needs to have detected the MiChroSat Enclosure prior to reading/ updating any of the parameters.

### User comms

Defines the operating baud rate of the user equipment

## 7 TROUBLESHOOTING

In order for your MiChroSat modem to function correctly and to successfully place or receive calls, the following initial conditions must be met:

- The MiChroSat modem must contain a valid Iridium SIM card which has been correctly activated for the intended services required. (Note: By default SIMs are activated for circuit switched data only).
- The correct SIM PIN code must have been entered or the SIN PIN request must have been disabled.
- The MiChroSat modem must be registered on the satellite network.
- The MiChroSat modem must report a minimum signal coverage of 1 (equivalent to 1 bar displayed on the handset).
- The power supply used with the MiChroSat modem must be able to deliver a minimum of 2.5 Amps at the requisite voltage.
- The antenna must be installed in a suitable location, providing a clear view of the sky (as detailed in section 2.1.11 of this manual).

The following FAQ's will also assist in troubleshooting communications problems, for further assistance please review the FAQ section of the MiiChroSat website ([www.MiChroSat.com](http://www.MiChroSat.com)) which is regularly updated or contact Wireless Innovation directly.

### 7.1 Frequently asked Questions

#### 7.1.1 How can I tell if my MiChroSat Modem is registered on the satellite network?

It is possible to check if the MiChroSat modem is currently registered on the LEO network by issuing the following AT command **AT+CREG?**

The modem will respond with the following string **+CREG 000,'N'** where there are 4 possible values of 'N' that may be returned by the modem:

- 001 - The modem is registered on the Network.
- 002 - Modem is currently not registered but is searching for the network.
- 003 - Registration denied.
- 004 - Unknown

Note: The modem may take up to 30 seconds to respond

### 7.1.2 How can I check my MiChroSat modem signal strength?

It is possible to receive an indication of the RSSI - signal strength received by the modem by issuing the following AT command **AT+CSQ**.

The response will take the format **+CSQ:'N'** where has 6 possible values of 'N' that may be returned by the modem:

- 0 - No coverage.
- 1 - Equal to 1 bar displayed on 9505/9555 Iridium phone handset.
- 2 - Equal to 2 bars displayed on 9505/9555 Iridium phone handset.
- 3 - Equal to 3 bars displayed on 9505/9555 Iridium phone handset.
- 4 - Equal to 4 bars displayed on 9505/9555 Iridium phone handset.
- 5 - Equal to 5 bars displayed on 9505/9555 Iridium phone handset.

Note: The above command will not function unless the MiChroSat modem has registered with the Network. For most reliable call setup, Wireless Innovation recommend that a minimum reported signal strength of 3 be obtained prior to attempting to establish a call.

### 7.1.3 How can I check if my MiChroSat modem is waiting for a PIN code?

Using a terminal program e.g. HyperTerminal, connect to the modem, and verify the connection using the command AT. If the terminal program is correctly connected to the modem it should display the following reply OK.

To query the SIM card status to identify if a PIN code is required the following command should be issued **AT+CPIN?** .

The modem will typically reply with one of three different responses:

**+CPIN: SIM PIN**  
**+CPIN: SIM PIN2**  
 or  
**READY**

**SIM PIN:**

This means the modem is waiting for a SIM card PIN number to be entered. Note that the modem will not register or allow calls to be placed until a valid pin code has been entered.

**SIM PIN2 and READY:**

This command means that the correct SIM card PIN number has already been entered (or disabled) and the modem is now able to register with the Network.

#### 7.1.4 How do I remove the PIN code from my SIM?

If the SIM card PIN is required then the following command should be used to enter the pin code **AT+CPIN="<pin>"** (where the default pin = 1111).

If the modem accepts the pin code it will reply with OK.

In order to disable the requirement for SIM card PIN number to be entered at each boot of the MiChroSat modem, the following command should be used:

**AT+CLCK="SC",0,"<pin>"**

If the modem accepts the pin code it will reply with OK.

#### 7.1.5 My Terminal Software will not communicate with the MiChroSat Modem?

Details of how to configure Windows HyperTerminal to communicate with the MiChroSat modem are included in section 6 of this manual, however the following points may assist with communications problems with alternate terminal software:

- Is the MiChroSat modem correctly powered (not in sleep/standby mode) and is the indicator LED illuminated to indicate that the modem is powered on/registered on the satellite network?
- Is the correct serial port (comm.-port) selected within the terminal application? Are the serial port communications setting set correctly (default settings are 9600,8,N,1 with no flow control)?
- Is the pin-out of your communications cable correct (sample cable pin-outs are provided in Appendix A of this manual)? Note that Michroface configuration cable supplied with the MiChroSat modem cannot be used for general serial communications.
- Are you using a USB-Serial adapter? Ensure that the drivers are correctly configured and that the serial interface provides full RS-232 signal emulation.

#### 7.1.6 The Michroface software will not communicate with the MiChroSat Modem?

The Michroface software will automatically check for connections to a MiChroSat modem on all available RS-232 communications ports on the PC , however if a connection cannot be established verify the following:

- Ensure that no other serial applications (such as terminal programs) are running at the same time as the Michroface software as these may block access to the required serial port.

### 7.1.7 How should I format the number I am trying to dial from my MiChroSat Modem?

The full international dialling format must be used when dialling to or from a MiChroSat modem, regardless of the location where the modem is making the call.

For example to dial the following US phone number: 858 587-1121, the modem would be programmed with the full international dialling code (001 for North America) as follows:

**atdt0018585871121**

To dial from one MiChroSat modem to another MiChroSat modem the full international Iridium dialling code (8816) must still be used, therefore to dial the modem with MSISDN/C 881693124213.

**atdt00881693124213**

To dial a MiChroSat modem from PSTN, the full international access format for the country from where the call is originated must be used since it will be treated as an international call.

### 7.1.8 How do I configure my MiChroSat modem to automatically answer incoming calls?

The MiChroSat modem may be configured to automatically answer incoming calls, by entering **AT+S0=1**, this will force all data calls to be answered after 1 ring.

This command may also be added to the boot initialization string within Michroface controller using the Michroface software to ensure the modem is always programmed to operate in this manner at boot.

### 7.1.9 Are there any special requirements when making calls to/from MiChroSat Modems from PSTN or GSM?

If dialing from PSTN to MiChroSat, it is always recommended that a direct analogue subscriber line (POTS Line) is used to place/receive calls as PABX's may cause compatibility issues from PSTN modem to Iridium Gateway, for reference the bearer service provided by any PABX circuit must 3.1KHz audio.

It should also be noted that many Least Cost Routing services offered by service providers use Voice Over IP (VOIP) circuits which do not support circuit switched data calls.

The end-to-end data call quality and probability of connection is governed by the ability of the modem relay equipment at the satellite gateway to synchronise with modems at the originating location. Modem synchronisation is directly impacted by voice compression that is used by international telephony carriers.

For optimal reliability and connectivity, Wireless Innovation Ltd recommends that wherever practically possible closed network calling from MiChroSat modem to MiChroSat modem be used.

**7.1.10 Are there any test numbers I can call from my MiChroSat modem to verify my configuration?**

The Iridium satellite network provides a dedicated test number for voice/audio services that may be called from your MiChroSat modem (if voice has been provisioned) using the dedicated voice handset .

Voice Test Number: **00-1-480-752-5105**

To test circuit switched data calls, no dedicated number is provided, however circuit switched test may be completed by dialling the Direct Internet number, calls to this number are automatically answered by a dedicated bank of modems hosted in the satellite gateway, so allow a user to verify that the MiChroSat modem is functioning correctly and is able to correctly place calls.

Data Test Number: **008816000025**

(Note test calls to this number will automatically be dropped after approximately 30 seconds).

A successfully connected call from Hyperterminal or similar will return a 'CONNECT' message when the connection is successfully established.

Please note that calls to either of these numbers may be charged by service provider at standard network rates.

Contact Details

Wireless Innovation Ltd  
Unit D2  
Churcham Business Park  
Churcham  
Gloucestershire  
GL2 8AX  
United Kingdom

Phone: +44 (0) 1452 751940  
Fax: +44 (0) 1452 751941  
E-mail: [msat@wi-ltd.net](mailto:msat@wi-ltd.net)  
Web: [www.MiChroSat.com](http://www.MiChroSat.com)